



User Manual

AS1-3KS-5.1

Content

.....	- 1 -
CHAPTER 1 SAFETY PRECAUTIONS	- 3 -
1.1 SAFETY TIPS	- 3 -
1.2 SYMBOLS INSTRUCTIONS	- 5 -
CHAPTER 2 PRODUCT INTRODUCTION	- 6 -
2.1 SCOPE OF APPLICATION	- 6 -
2.2 PRODUCT MODEL DESCRIPTION	- 7 -
2.3 DATASHEET	- 7 -
CHAPTER 3 INSTALLATION INSTRUCTIONS.....	- 9 -
3.1 SAFETY TIPS	- 9 -
3.2 DETERMINE THE INSTALLATION METHOD AND LOCATION	- 10 -
3.3 INSTALLATION STEPS	- 12 -
CHAPTER 4 ELECTRICAL CONNECTIONS.....	- 17 -
4.1 ELECTRICAL INTERFACE DESCRIPTION	- 17 -
4.2 SYSTEM WIRING SCHEMATIC	- 18 -
4.3 MASTER DEVICE WIRING	- 18 -
4.4 SLAVE DEVICE WIRING	- 19 -
4.5 COMMUNICATION INTERFACE DESCRIPTION	- 21 -
CHAPTER 5 DEBUGGING INSTRUCTIONS	- 23 -
5.1 HUMAN-COMPUTER INTERFACE INTRODUCTION	- 23 -
5.2 SYSTEM COMMISSIONING	- 24 -
5.3 REMOTE MONITORING	- 24 -

CHAPTER 6 FAULT CODES AND COMMON TROUBLESHOOTING	- 24 -
CHAPTER 7 BATTERY MAINTENANCE	- 27 -
7.1 TRANSPORTATION	- 27 -
7.2 STORAGE	- 27 -
CHAPTER 8 CONTACT US	- 29 -
WARRANTY CARD	- 30 -

Chapter 1 Safety Precautions

This user manual describes the instructions and procedures for the installation of the AS1 AC Retrofit Battery System. Please read the user manual before operating it.

Keep this user manual properly and operate strictly according to all safety tips and operation instructions in this manual.

1.1 Safety Tips



Danger

- Electric shock and high voltage.
- Do not touch live components, as this may result in burns or death.
- To prevent electric shock during installation and maintenance, make sure that the AC and DC ports are disconnected.
- When the casing is wet, do not touch the casing of the inverter, which may present a risk of electric shock.
- Before opening the case, the machine must be disconnected from the grid and battery; disconnect the power supply for at least five minutes for the capacitor to fully discharge before opening the case.



Warning

- Installation, repair, recycling, and disposal of AS1 must be performed by qualified personnel in accordance with national and local standards and regulations.
- Any behavior to change the functionality of the product without permission will cause fatal injury to the operator, third parties, and

equipment. SAJ is not responsible for these losses and warranty claims.

- To ensure property and personal safety, the battery modules and inverter shall be well grounded.









 **Caution**

- Do not modify or tamper with AS1 and other components of the system.
- Please pay attention to the risks caused by improper modification.

 **Notice**

- This device has a built-in lithium battery and a dedicated extended battery. Do not extend other brands of batteries at the battery port.
- AS1 outputs AC power directly to the utility grid side and the backup loads side. Do not reverse output of the two AC terminals of the inverter.

1.2 Symbols instructions

Symbol	Description
	Dangerous electrical voltage The device is directly connected to public grid, thus all work to the battery shall only be carried out by qualified personnel.
	No open flames Do not place or install near flammable or explosive
	Danger of hot surface The components inside the device will release a lot of heat during operation. Do not touch metal plate housing of the inverter during operating.
	Attention Install the product out of reach of children
	An error occurred Read the usage manual to troubleshoot problems
	This device SHALL NOT be disposed of in residential waste Please go to Chapter 8 “Recycling and Disposal” for proper treatment.
	CE Mark The device is in compliance with Low Voltage Directive
	Recyclable

Chapter 2 Product Introduction

2.1 Scope of application

AS1 series is used in energy storage retrofits and is a new type of AC coupled energy storage system. The built-in lithium battery inside AS1 can be expanded in capacity according to user demands, and the modular design of the slave device makes it easy to install wiring.

In daytime, solar power supports the loads first while the surplus power will be stored by AS1, to improve self-consumption rate.

In peak power price hours, power from AS1 supports the loads; while in valley power price hours, AS1 is charged by the grid. Finally a balance could be realized. In case of grid fault, AS1 will make sure no outage in the loads, achieving UPS function

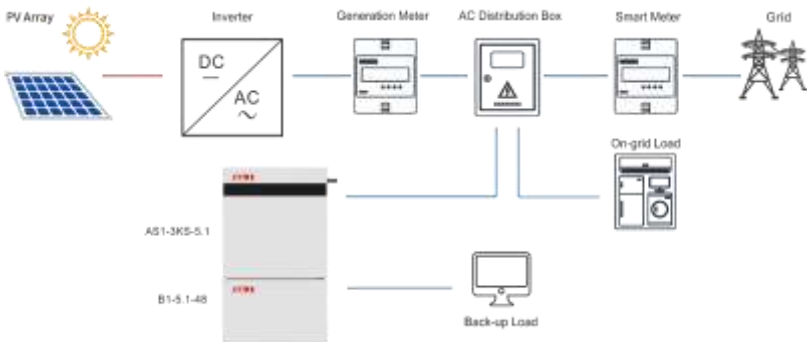

Fig. 2.1 System composition diagram

2.2 Product Model Description

AS1 – XK S – XX

① ② ③ ④

- ① AS1 represents the product series.
- ② XK indicates the rated power of the product XkW, such as 3K for 3kW.
- ③ S represents single phase; T represents three phase.
- ④ Indicates the built-in battery capacity, such as 5.1 for 5.1kWh.

2.3 Datasheet

AS1-3KS-5.1

Type	AS1-3KS-5.1
Battery Data	
Battery Type	Lithium ion
Total Energy Capacity[Wh]	5120
Battery Capacity [Ah]	100
Rated Voltage [V]	51.2
Voltage range [V]	42~58.4
Depth Of Discharge[DOD]	≤90%
Cycle Life	≥6000
Max.Charge Current [A]	60
Max.Discharge Current [A]	60
Scalability	Yes (up to 20kWh)
Grid Data	
Max. Continuable Output Power [VA]	3000
Max.Output Current [A]@230Vac	13.1
Max.Output Fault Current [A]	28
Inrush Current [A]	50
Max.Output Overcurrent Protection [A]	28
Rated Grid/Backup Voltage/Range [V]	220, 230, 240/180-280

Rated Grid/Backup Frequency/Range [Hz]	50, 60/±5
Power factor [cos φ]	0.8 leading~0.8lagging
Feed-in	L+N+PE
AC Output [Back-up Mode]	
Max. Continuable Output Power [VA]	3000
Output Voltage [V]	220/230/240
Max.Output Current [A]@230Vac	13.1
Output Frequency [Hz]	50/60
Max.Output Power [VA]	3600 ,10sec
General Data	
Communication Mode	Wi-Fi/4G/Ethernet(Optional)
Operating Temperature Range	0 °C~50 °C
Cooling Method	Natural Convection
Ambient Humidity	0-95% Non-condensing
Noise[dBA]	<29
Ingress Protection	IP65
Dimensions [H*W*D][mm]	738*650*186
Weight [kg]	60
Standard Warranty [Year]	5(Battery 7 year)
Applicable Standard	AS 4777.2, VDE 4105, G98, C10/C11, CEI0-21, IEC 62619, IEC 62040

Chapter 3 Installation Instructions

3.1 Safety Tips

**Danger**

- Potential fires and electric shocks that are life threatening.
- Do not place any flammable or explosive materials beside AS1.
- Equipment connected to high-voltage power generation equipment must be performed by qualified personnel in compliance with national and local standards and regulations.

**Notice**

- The pollution level applicable to AS1 is Class II.
- Inappropriate or inconsistent installation environment can shorten the life of AS1.
- Do not install AS1 directly by exposing it under strong sunlight.
- Please do not install in damp places.
- The installation location must be well ventilated.
- AS1-3KS-5.1 (hereinafter also referred to as the master device) can be used independently. If the battery capacity needs to be expanded, please use B1-5.1-48 (slave device), and maximum 3 slave devices can be accessed.

3.2 Determine the installation method and location

3.2.1 AS1 series product dimension

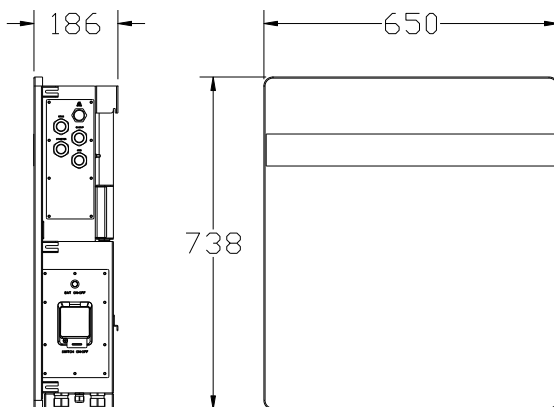

Fig. 3.1 AS1-3KS-5.1 appearance and dimension diagram

3.2.2 AS1-3KS-5.1 is cooled by natural wind convection. It is recommended to install in indoors or sheltered areas to avoid direct sunlight, rain and snow.

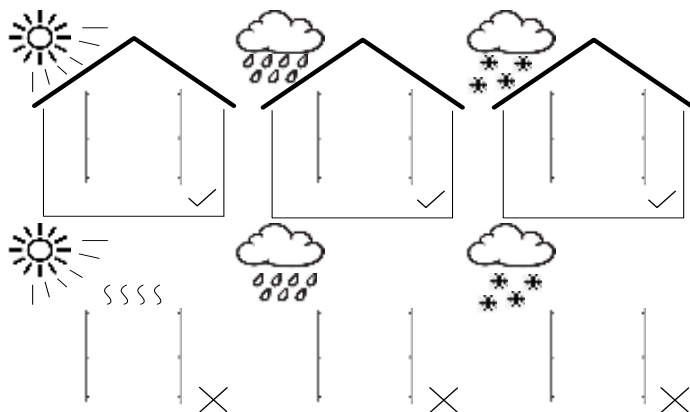

Fig. 3.2 Installation tips

3.2.3 Vertical ground mounting method is recommended and it's allowed to be installed by maximum tilting 15°backward. Do not install it horizontally or reversely.

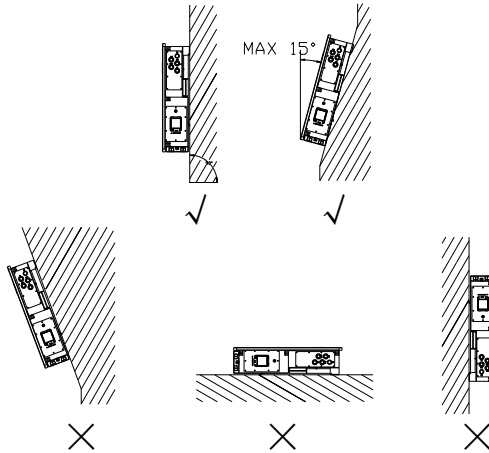

Fig. 3.3 Installation angle

3.2.4 Please ensure that the air at the installation point is circulated. Bad air ventilation will affect the working performance of internal electronic components and shorten the service life of AS1.

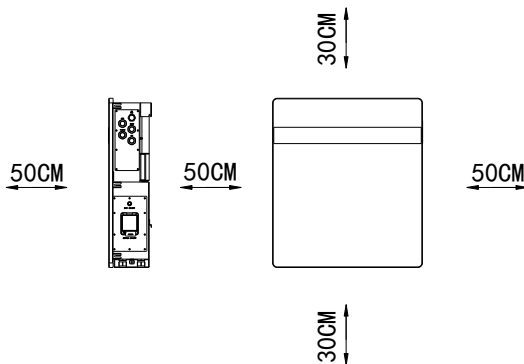

Fig. 3.4 Installation distance

3.3 Installation steps

3.3.1 Determine the mounting hole position of the hanging panel

The AS1 series is mounted on a hanging panel. The mounting position is determined according to the position of the hanging hole on the hanging panel. Unit: mm.

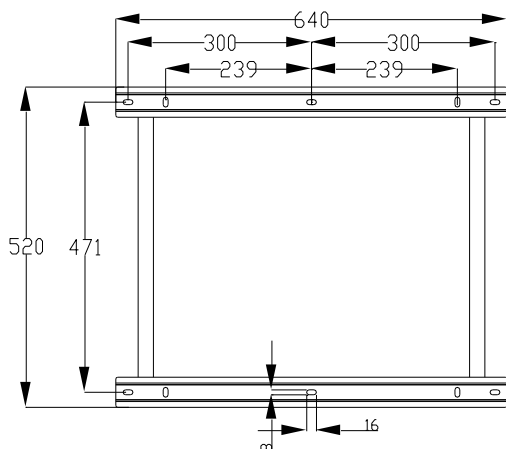

Fig. 3.5 AS1- 3KS-5.1 hanging panel size (master device)

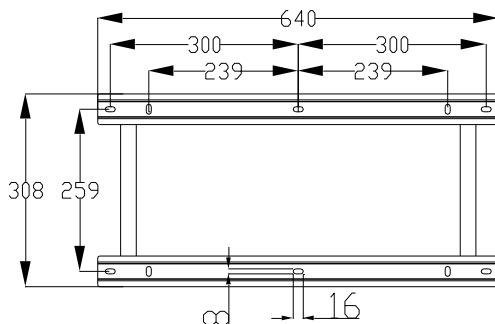

Fig. 3.6 B1-5.1-48 hanging panel dimension (slave device)

Before installation, please make sure that the wall has sufficient strength to fix the screws and bear the weight of AS1. Mark the hanging hole position of the hanging panel on the wall and drill the corresponding hole position; then use a rubber hammer to drive the screw fixing seat into the hole.

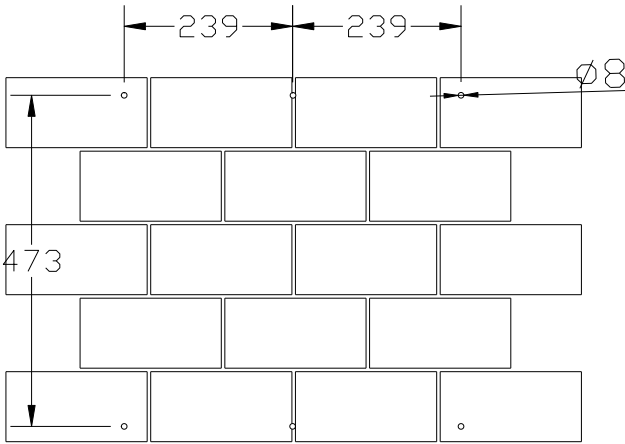

Fig. 3.7 AS1-3KS-5.1 (master device)

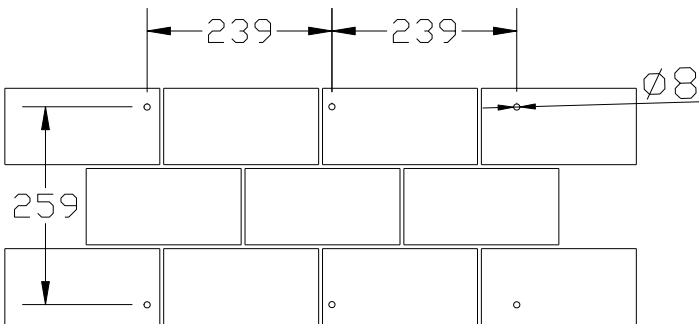

Fig. 3.8 B1-5.1-48 hanging panel dimension (slave device)

AS1-3KS-5.1 is the master device and B1-5.1-48 is the slave device. In order to ensure

normal installation of both, the installation distance between the master and the slave panel, while that between the slave panels shall at least meet requirements as follows:

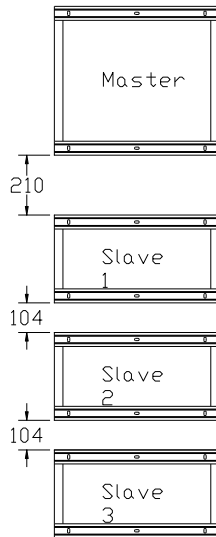

Fig. 3.9 Distance between hanging panels

Fix the hanging panel with hex head screw on the installation position.

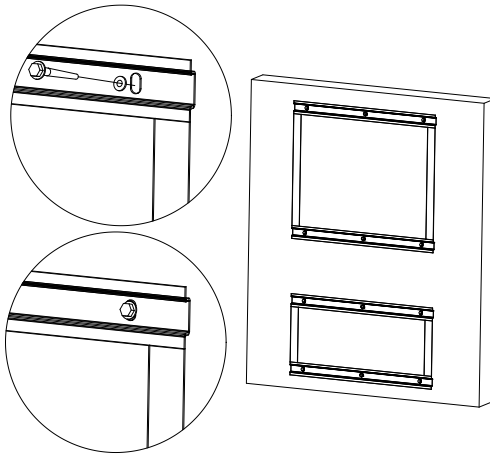

Fig. 3.10 Fixing the hanging panel

Please pay attention when installing the device. Please install the slave device first and then install the master device. In case the distance between the master device and the slave device is not enough, installation can't be done. Carefully attach the device to the hanging panel and make sure the bottom of the device fits snugly with the panel.

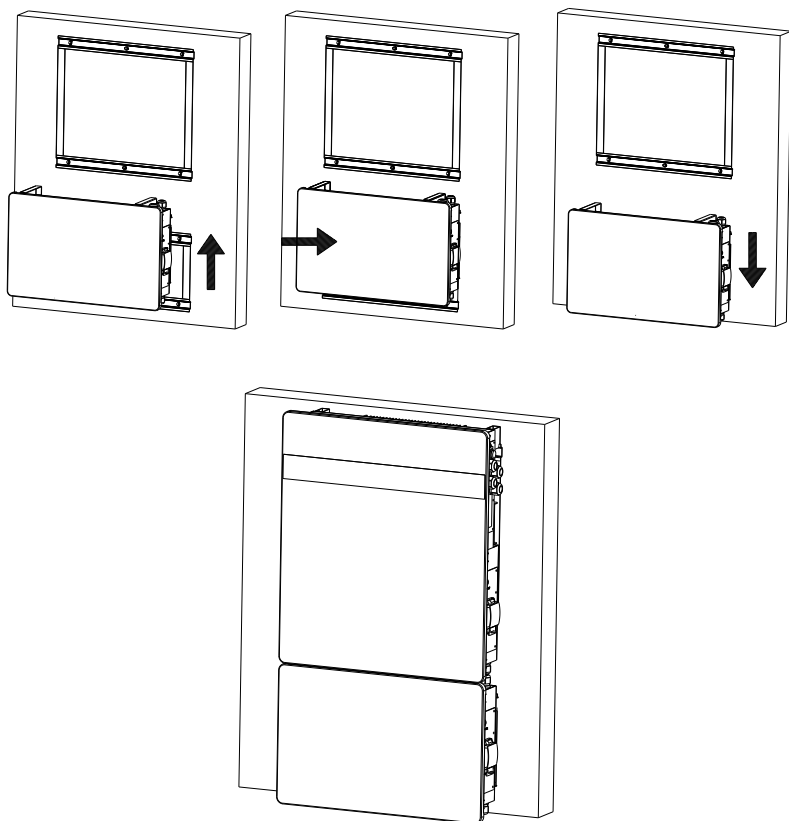

Fig. 3.11 Install AS1-3KS-5.1

Chapter 4 Electrical Connections

4.1 Electrical Interface Description

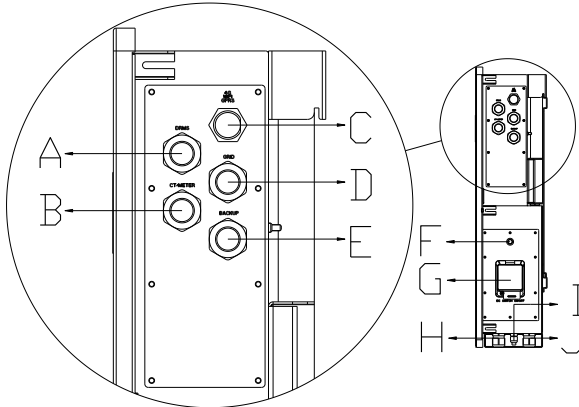

Fig. 4.1 AS1-3KS-5.1 electrical interfaces

Code	Name
A	DRMS Port
B	CT/Meter connection
C	RS232 communication
D	Grid connection
E	Backup connection
F	BMS switches
G	Battery switches
H	BAT+
I	BMS LINK
J	BAT-

Table 4.1 Interface description

4.2 System Wiring Schematic

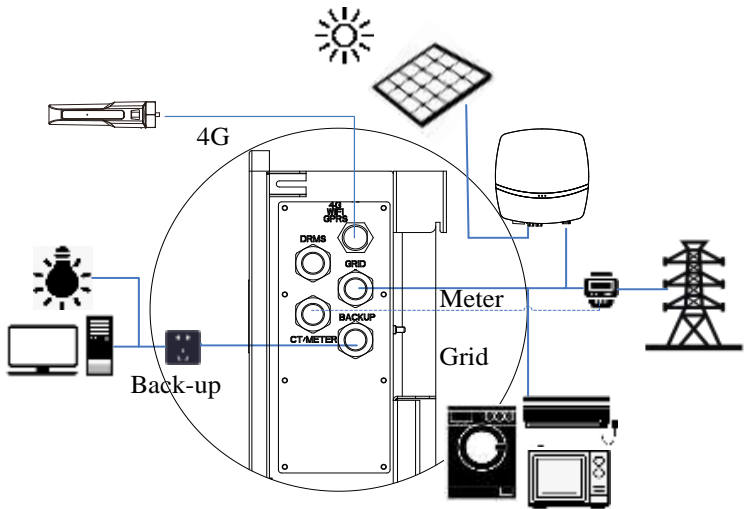

Fig. 4.2 Wiring schematic diagram

Don't connect the backup loads side with the grid or battery

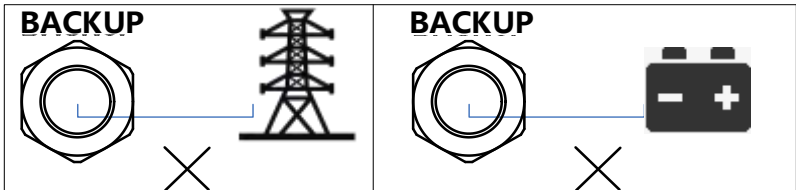

Fig. 4.3 Wrong connection example

4.3 Master Device Wiring

When wiring the master device, you need to disassemble the wiring cover in the upper right corner and connect as per the terminal identification.

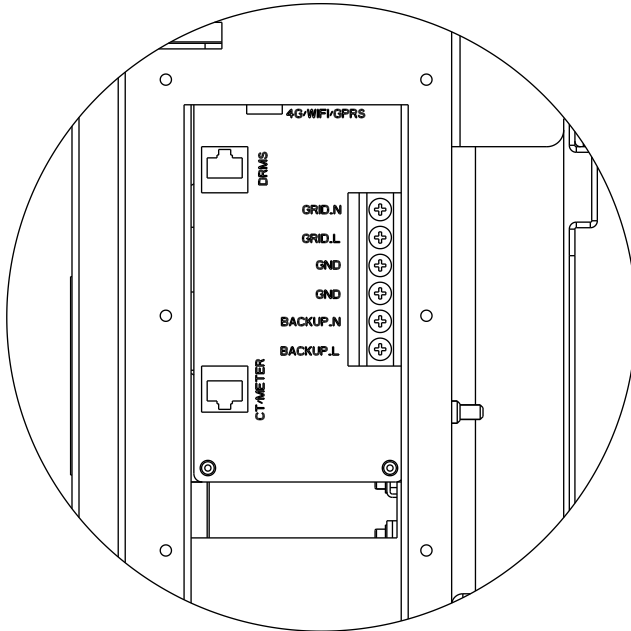

Fig. 4.4 Master device wiring terminals

4.4 Slave Device Wiring

More capacity is required to connect the slave devices in parallel. Disconnect the battery connector cover of the master device and the slave unit before wiring. Only 3 lines are required to connect a slave device. (BAT+-BAT+, BAT--BAT-, LINK-LINK)

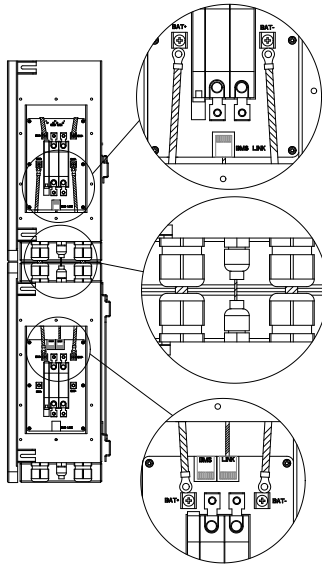

Fig. 4.5 Slave device wiring terminals



Notice

Please use the battery cable in original package.

Do not share 1 lithium battery slave device on 2 AS1.

4.5 Communication Interface Description

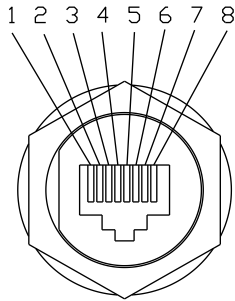

Fig. 4.6 DRMS pins

Pin number	Name
1	DRM1/5
2	DRM2/6
3	DRM3/7
4	DRM4/8
5	REF GEN/0
6	COM LOAD/0
7	NC
8	NC

Table 4.2 DRMS pins description

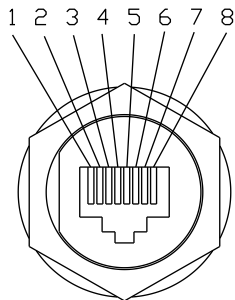

Fig. 4.7 CT/Meter pins

Pin number	Name
1	R485_A
2	R485_B
3	PV_CT-
4	PV_CT+
5	Grid_CT-
6	Grid_CT+
7	NC
8	NC

Table 4.3 CT/Meter pins description

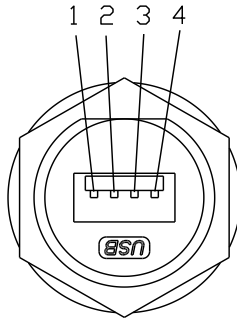

Fig. 4.8 RS232 pins

Pin number	Name
2	RS-232 TX
3	RS-232 RX
4	GND

Table 4.4 RS232 pins description

Note: The RS232 interface can be connected to the eSolar GPRS/4G/WiFi module. For operation details, please refer to the quick installation guide of each monitoring module.

Chapter 5 Debugging Instructions

5.1 Human-computer Interface Introduction

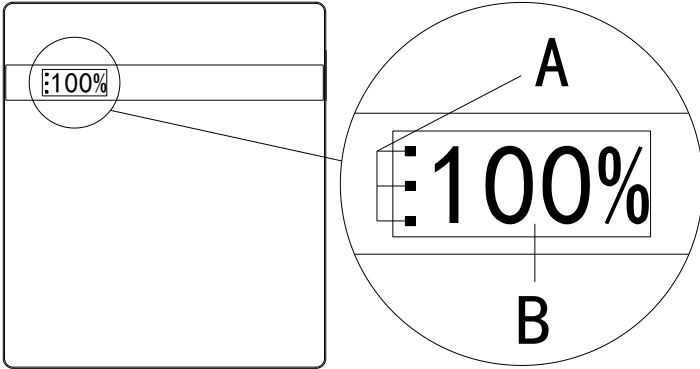

Fig. 5.1 Human-computer interface

	LED lamps state		Description
A	Green/Red LED lamp	Green lamp flicker from bottom to top	Battery discharging
		Green lamp flicker from top to bottom	Battery charging
		Red lamp flicker:1 s/time	Standby
		Green lamp and red lamp flicker in alternative	Procedures are being upgrade
		Red lamp Always light on	Faults in device
B	Residual battery capacity percentage (SOC)		Total remained battery capacity of the system

Table 5.1 Human-computer interface description

5.2 System commissioning

After finishing connecting wiring, please install the communication modules. Use eSolar O&M software to realize initialization of the device. (Terminal users please check relevant info by eSolar Air)

Notice: before starting slave device, open the battery switches and BMS switches first.

5.3 Remote monitoring

The eSolar 4G/WiFi/Ethernet module are connected to the Internet, and the inverter data is uploaded to the server. The user can remotely monitor the inverter operation info through the web version of the Web Portal or mobile of user.

Chapter 6 Fault Codes and Common Troubleshooting

	Explanation	Fault type
01	Communication loss of the main and subordinate machine Master	Error
02	High temperature Master	Error
03	Low temperature Master	Error
04	DCI Err Master	Error
05	Synchronizing pulse fault Master	Error
06	Relay fault Master	Error
07	Storage fault Master	Error
08	Battery input short circuit Master	Error
09	Battery overvoltage Master	Error
10	Battery open circuit Master	Error
11	DC side hardware overcurrent Master	Error
12	Battery discharging fault Master	Error
13	Battery controller overcurrent Master	Error
14	Bus soft-start timeout Master	Error
15	Bus voltage high Master	Error
16	Bus voltage low Master	Error
17	Bus voltage high of hardware Master	Error
18	Inverter overcurrent Master	Error
19	Inverter hardware overcurrent Master	Error
20	Inverter short circuit fault Master	Error
21	Output overload Master	Error
25	Voltage of grid high warning Master	Alarm
26	Voltage of grid low warning Master	Alarm
27	Frequency of grid high warning Master	Alarm
28	Frequency of grid low warning Master	Alarm
29	Grid loss warning Master	Alarm
30	Grid average overvoltage within 10 mins Master	Alarm

31	Overload alarm Master	Alarm
33	Fan Err Slave	Error
34	Output terminal abnormal Slave	Error
35	Inverter voltage wave form fault Slave	Error
49	Grid voltage consistent alarm Slave	Alarm
50	Grid frequency consistent alarm Slave	Alarm
51	GND Loss Warn	Alarm
52	LN Wrong Warn	Alarm
53	CAN communication loss Slave	Alarm
54	Low battery SOC alarm Master	Alarm
55	Voltage of battery high alarm Master	Alarm
56	Voltage of battery low alarm Master	Alarm
57	Voltage of grid high warning Slave	Alarm
58	Voltage of grid low warning Slave	Alarm
59	Grid over frequency alarm Slave	Alarm
60	Grid under-frequency alarm Slave	Alarm
61	Grid loss alarm warning Slave	Alarm
65	Communication loss of the main and subordinate machine Slave	Error
66	Storage fault Slave	Error
67	RTC fault Slave	Error
68	BMS equipment fault Slave	Error
81	Unit cell over-voltage alarm Slave	Alarm
82	Unit cell under-voltage alarm Slave	Alarm
83	Over charging current alarm Slave	Alarm
85	Over discharging current alarm Slave	Alarm
86	Over discharging temperature alarm Slave	Alarm

87	Over charging temperature alarm Slave	Alarm
88	Battery low voltage alarm Slave	Alarm
89	BMS communication loss alarm Slave	Alarm
91	Ammeter communication loss alarm Slave	Alarm
92	DRM0 alarm Slave	Alarm

Chapter 7 Battery maintenance

7.1 Transportation

Lithium batteries are dangerous goods. Passed the test of UN38.3, this product meets the transportation requirements for dangerous goods for lithium batteries. After the installation of the battery on site, the original packaging (contains the lithium battery identification) should be kept. When the battery needs to be returned to the factory for repair, please pack the battery with the original packaging to reduce unnecessary trouble.

7.2 Storage

After purchasing the battery, please store it with following instructions:

- 1) Please store it in a dry and ventilated environment, keep it away from heat sources;
- 2) Please keep it in an environment with storage temperature as $-20\text{ }^{\circ}\text{C} \sim 50\text{ }^{\circ}\text{C}$, humidity $<85\%$ RH;
- 3) For long-term storage (>3 months), please put it in an environment with a temperature of $18\text{ }^{\circ}\text{C}$ to $28\text{ }^{\circ}\text{C}$ and a humidity of $<85\%$ RH;
- 4) The battery should be stored in accordance with the storage requirements mentioned above, and the battery should be installed within 6 months since delivered from the factory and used with compatible inverters;

Notice



- The battery remains 60% power when it is sent from the factory.
- The longer the battery is stored, the DOD value is getting bigger. When the battery remaining voltage fails to reach the startup voltage requirement, the battery may be damaged.
- Judgment condition: Close the battery breaker switch and press the BMS switch. At this time, if the LED light is flashing, it is running normal. If the LED light is off, the battery is in faulty.

The battery cannot be disposed of as household refuse. When the service life of the battery reaches to the limit, it is not required to return it to the dealer or SAJ, but it must be recycled to the special waste lithium battery recycling station in the area.

Chapter 8 Contact Us

Guangzhou Sanjing Electric Co., Ltd.

Headquarter: SAJ Innovation Park, No.9, Lizhishan Road, Science City, Guangzhou High-tech Zone, Guangdong, P.R.China.

Jiangxi Factory: Building D10, D11, Ganzhou International Port Electronic Info Industrial Park, Longling Town, Nankang District, Cangzhou City, Jiangxi Province

Website: <http://www.saj-electric.com/>

Technical support & service hotline: 400-960-0112

Fax: 020-66608589

Email: service@saj-electric.com

International sales

Tel.: 86-20-66608618/66608619/66600082/66600086

Fax: 020-66608589

Email: info@saj-electric.com

Domestic sales

Tel.: 020-66600058/66600082

Fax: 020-66608589

Warranty Card

The installer should fill in the second form while installing the inverter. For warranty claim, please complete the below forms and send this page to SAJ, attached with the Customer's invoice.

For customer to fill in

Name:		
City:	Country:	Zip:
Tel:	Fax:	E-mail:

Information on device

Device type:	Serial No.(S/N):
Invoice No:	Commissioning date:
Fault time:	
Error message (Display reading):	
Brief fault description & photo:	
Signature: _____ Date: _____	



For installer to fill in

Modules used:		
Modules per string:	No. of string:	
Installation company:	Contractor license number:	
Company:		
City:	Country:	Zip:
Tel:	Fax:	E-mail:
Signature: _____ Date: _____		



Guangzhou Sanjing Electric CO., LTD.

ADD: SAJ Innovation Park, No.9, Lizhishan Road, Science City,
Guangzhou High-tech Zone, Guangdong, P.R.China (Zip: 510663)

Tel: +86 20 6660 8588 Fax: +86 20 6660 8589

Web: <http://www.saj-electric.com>

Edition No: V1.0